

The Structural Framework of the Southern Adirondacks

James McLelland

Department of Geology, Colgate University, Hamilton, NY

INTRODUCTION

The area referred to as the southern Adirondacks is shown in Figure 1. Within this region, the Precambrian is bounded approximately by the towns of Lowville and Little Falls on the west and Saratoga Springs and Glens Falls on the east.

Mapping in the southern Adirondacks was done first by Miller (1911, 1916, 1920, 1923), Cushing and Ruedemann (1914), Krieger (1937), and Cannon (1937); more recent investigations were undertaken by Bartholomé (1956) Thompson (1959), Nelson (1968), and Lettney (1969). At approximately the same time Walton (1961) began extensive field studies in the eastern portion of the area (Paradox Lake, etc.), de Waard (1962) began his studies in the west (Little Moose Mt. syncline). Subsequently de Waard was joined by Romey (de Waard and Romey, 1969).

Separately and together, Walton and de Waard (1963) demonstrated that the Adirondacks are made up of polydeformational structures, the earliest of which consist of isoclinal, recumbent folds. Their elucidation of Adirondack geology set the tone for future workers in the area. In this regard one of their most important contributions to the regional picture was that the stratigraphy of the west-central Adirondacks is similar to that of the eastern Adirondacks.

Beginning in 1967 McLelland (1969, 1972) initiated mapping in the southernmost Adirondacks just to the west of Sacandaga Reservoir. This work was extended subsequently north and east to connect with that of Walton and de Waard. Geraghty (1973) and Farrar (1976) undertook detailed mapping in the eastern half of the North Creek 15' quadrangle. This tied into investigations in the Brandt Lake region by Turner (1971). Recently, Geraghty (1978) completed a detailed study of the structure and petrology in the Blue Mt. Lake area.

The foregoing investigations have increased our knowledge of the southern Adirondacks, and this fieldtrip is designed to show as many examples of the region's structure, lithology, and petrology as time allows.

STRUCTURAL FRAMEWORK OF THE SOUTHERN ADIRONDACKS

The southern Adirondacks (Figs. 2-5) are underlain by multiply deformed rocks which have been metamorphosed to the granulite facies. The structural framework of the region consists of four unusually large fold sets, F_1 - F_4 (Fig. 2). Relative ages have been assigned to these fold sets, but no information exists concerning actual time intervals involved in any phase of the deformation. It is possible that several, or all of the fold sets, are manifestations of a single deformational continuum.

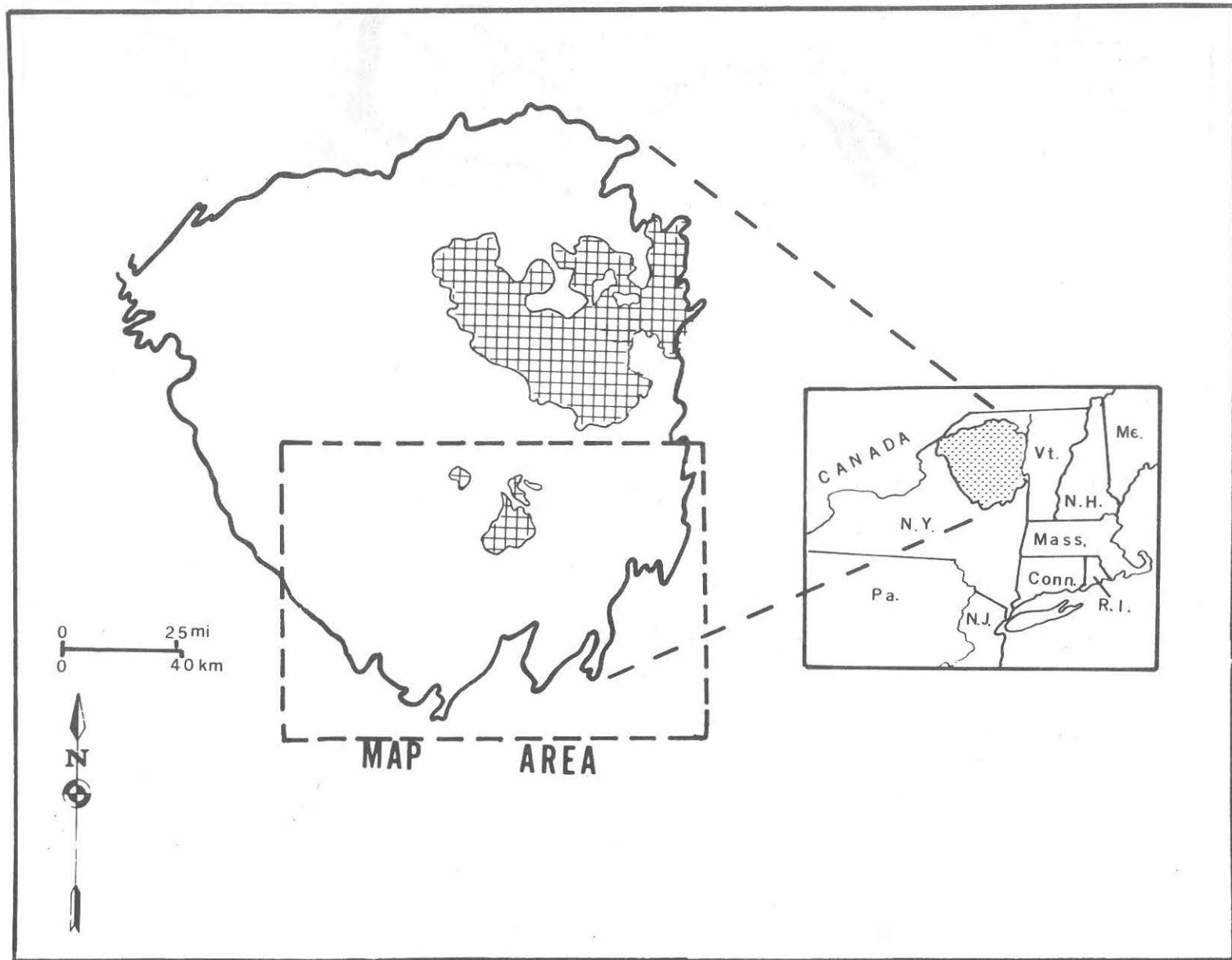

Fig. 1 - Location of central and southern Adirondacks. Anorthosite massifs patterned.

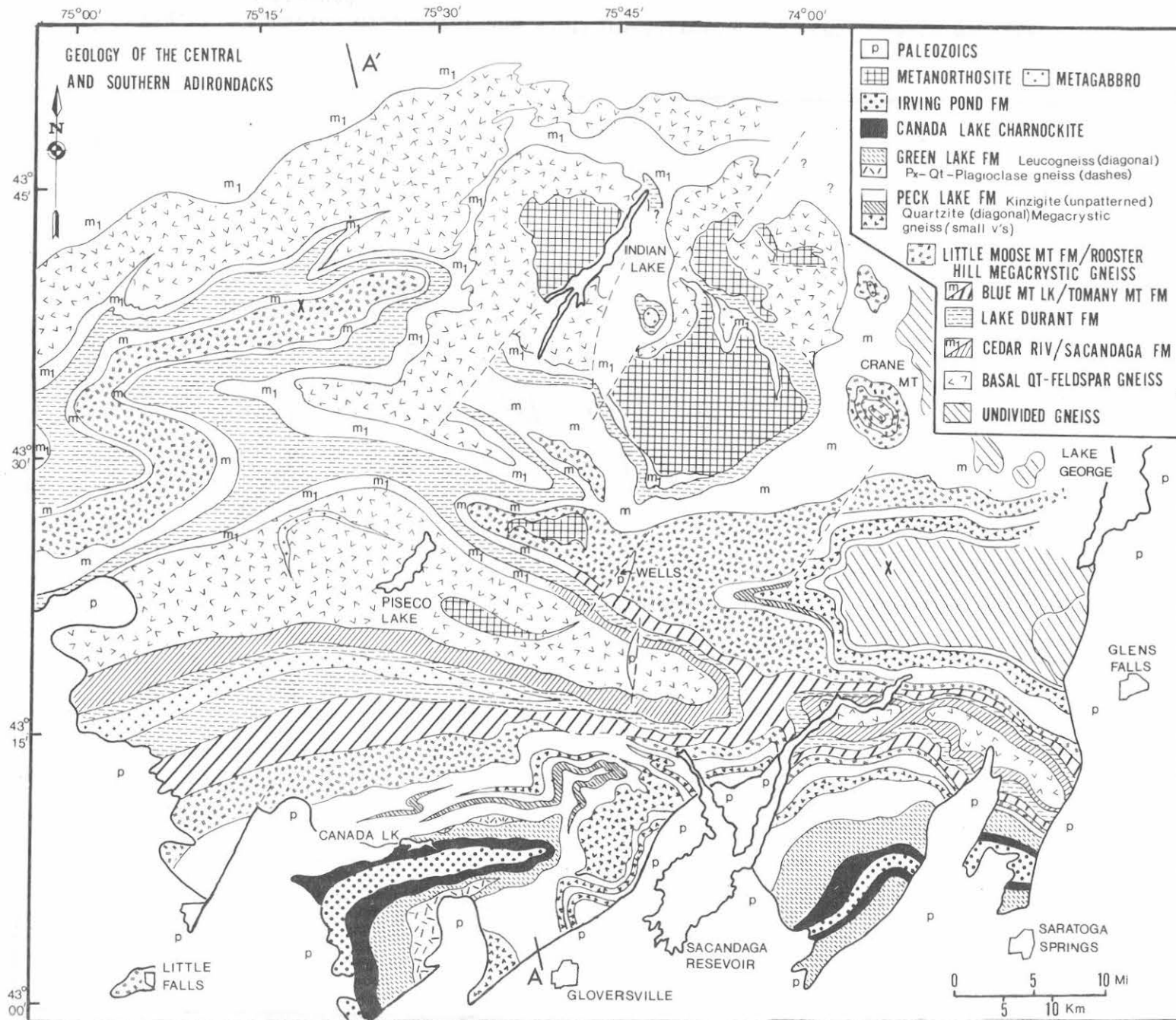

Fig. 2 - Geologic map of the central and southern Adirondacks showing distribution of formational units. The two X's locate bodies of meta-gabbro referred to in text.

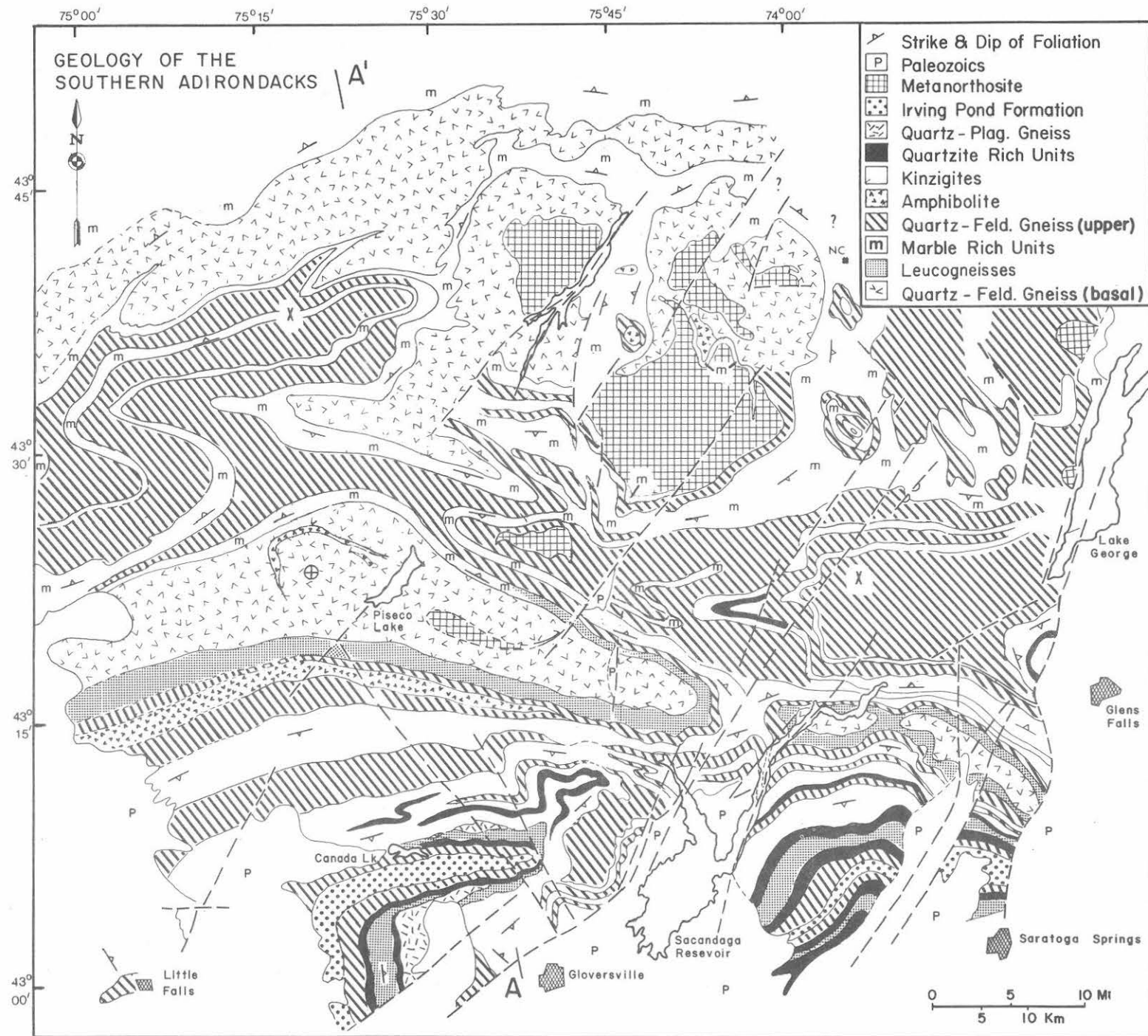

Fig. 3 - Geologic map of the central and southern Adirondacks showing distribution of lithologies throughout area. Major faults shown by dashed lines.

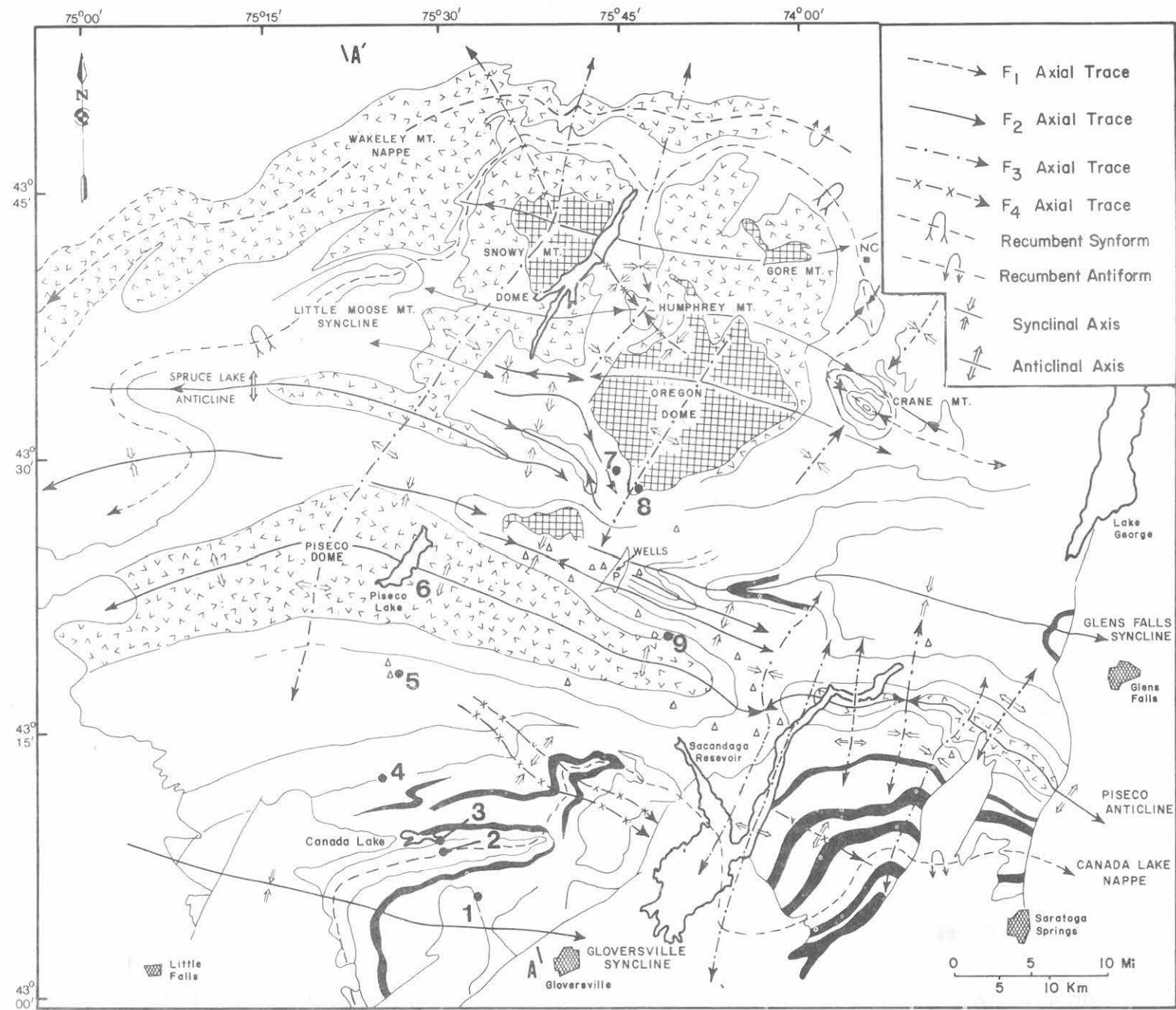

Fig. 4 - Structural framework of the central and southern Adirondacks showing the interference pattern produced by the four regional fold sets. The open triangles locate small anorthositic intrusives referred to in the text. Indicated numbers are those of stops.

The earliest and largest of these folds are recumbent, isoclinal structures (F_1) -- for example the Little Moose Mt. syncline (de Waard, 1962) and Canada Lake nappe (McLelland, 1969) (Figs. 2 and 5). These isoclines have axes that trend approximately E-W and plunge within 20° of the horizontal. As seen in Figure 5 the axial traces of each of the F_1 folds exceeds 100 km. They are believed to extend across the entire southern Adirondacks. Subsequent useage of the terms "anticline" and "syncline," rather than "antiform" and "synform," is based on correlations with rocks in the Little Moose Mt. syncline where the stratigraphic sequence is thought to be known (de Waard, 1962).

Close examination reveals that the F_1 folds rotate an earlier foliation defined principally by plates of F_1 quartz and feldspar. Although this foliation is suggestive of pre- F_1 folding, such an event does not seem to be reflected in the regional map patterns (Fig. 3). However, it is possible that major pre- F_1 folds exist but are of dimensions exceeding the area bounded by Figure 3. If this is the situation, their presence may be revealed by continued mapping. The existence of such folds is suggested by the work of Geraghty (1978) in the Blue Mt. area. In the vicinity of Stark Hills it seems that charnockites of the Little Moose Mt. Fm. may be identical to supposedly older quartzo-feldspathic gneisses (basal) which lie at the base of the lithologic sequence. Given this situation, then the Cedar River and Blue Mt. Lk. Fms. are identical, and there emerges a pre- F_1 fold cored by the Lake Durant Formation. However, careful examination of the Lake Durant Formation has failed to reveal the internal symmetry implied by this pre- F_1 fold model. It is possible, of course, that the pre- F_1 foliation may not be related directly to folding (e.g. formed in response to thrusting, gravity sliding, etc.; Mattauer, 1975). Currently the origin of the pre- F_1 foliation remains unresolved. In most outcrops the pre- F_1 foliation cannot be distinguished from that associated with the F_1 folding.

Following the F_1 folding, there developed a relatively open and approximately upright set of F_2 folds (Figs. 2 and 5). These are coaxial with F_1 . In general the F_2 folds are overturned slightly to the north, the exception being the Gloversville syncline with an axial plane that dips 45° N. The F_2 folds have axial traces comparable to those of the F_1 set. The Piseco anticline and Glens Falls syncline can be followed along their axial traces for distances exceeding 100 km until they disappear to the east and west beneath Paleozoic cover. The similarity in size and orientation of F_1 and F_2 suggests that both fold sets formed in response to the same force field.

The third regional fold set (F_3) consists of large, upright NNE folds having plunges which differ depending upon the orientation of earlier fold surfaces. The F_3 folds are observed to tighten as one proceeds towards the northeast.

The fourth fold set is open, upright, and trends NW. Within the area these folds are less prevalent than the earlier sets. However, Foose and Carl (1977) have shown that within the NW Adirondacks, northwest-trending folds are widespread and play an important role in the development of basin and dome patterns.

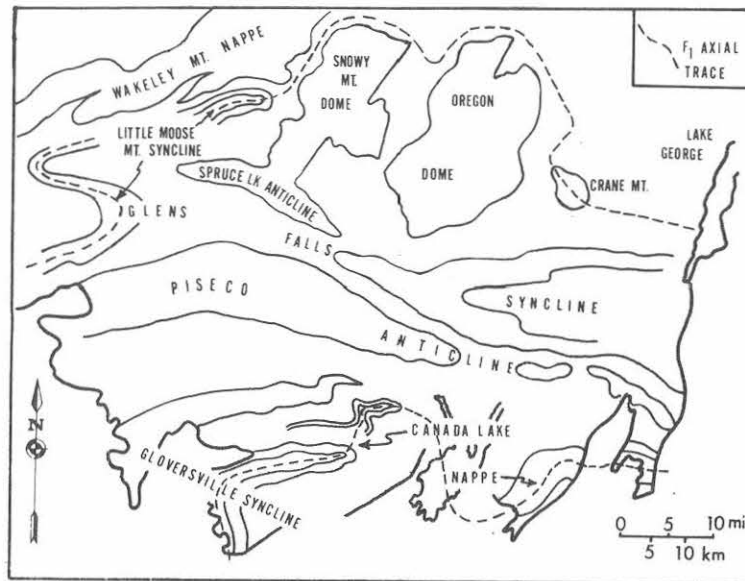

Fig. 5 - Blocked out major folds of the central and southern Adirondacks. The major F_1 -folds are the Wakeley Mt. nappe and the Canada Lake-Little Moose Mt. nappe whose axial trace is shown as a dashed trajectory.

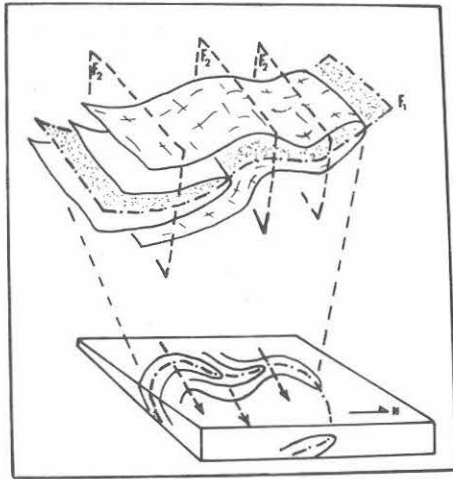

Fig. 6 - Three dimensional cartoon depicting the manner in which axial plane folding of the Canada Lake nappe effects the trajectory of the axial trace.

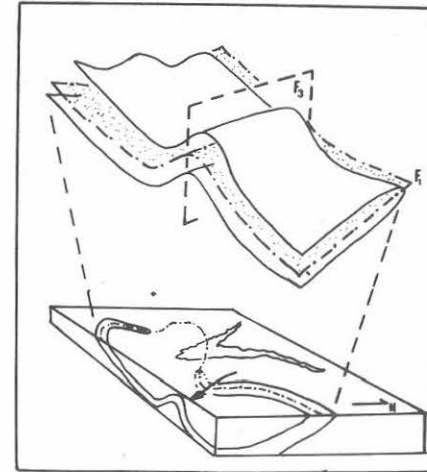

Fig. 7 - Three dimensional cartoon depicting the manner in which fold interference effects the axial trace of the Canada Lake nappe east of Sacandaga Reservoir.

The regional outcrop pattern is distinctive because of the interference between members of these four fold sets (Figs. 3 and 4). For example, the "bent-index-finger" pattern of the Canada Lake nappe west of Sacandaga Reservoir is due to the superposition of the F_2 Gloversville syncline on the F_1 fold geometry (Fig. 6). East of the reservoir the reemergence of the core rocks of the Canada Lake nappe is due to the superposition on F_1 of a large F_3 anticline whose axis passes along the east arm of the reservoir (Fig. 7). The culmination-depression pattern along the Piseco anticline results from the superposition of F_2 and F_3 folds. The structure of the Piseco dome is due to the intersection of the Piseco anticline (F_2) with the Snowy Mt. anticline (F_3). Farther to the north, Crane Mt. is a classic example of a structural basin formed by the interference of F_1 , F_2 , and F_3 synclines (Figs. 3 and 8).

DISCUSSION AND SYNTHESIS OF STRUCTURAL RELATIONSHIPS

Over a decade ago Walton and de Waard (1963) proposed that rocks of the anorthosite-charnockite suite comprise a pre-Grenvillian basement on which a coherent "supracrustal" sequence was deposited unconformably. Rocks which would be assigned a basement status in this model are designated as basal quartzo-feldspathic gneiss in Figure 3. The basal Cedar River Fm. of the overlying "supracrustal" sequence consists of marbles, quartzites, and various calc-silicates. This lowermost unit is followed upward by various quartzo-feldspathic gneisses, marbles, and other metasedimentary sequences shown in Figure 9. Although our own research agrees with the generalized lithologic sequences of de Waard and Walton, two major provisos are necessary and are given here.

(1) Anorthositic rocks intrude the so-called supracrustal sequence, and therefore the anorthosites post-date these units and cannot be part of an older basement complex (Isachsen, McLelland, and Whitney, 1976; Husch, Kleinspehn, and McLelland, 1976). The metastratified lithologies within the basal quartzo-feldspathic gneisses of Figure 2 are believed to be part of a layered sequence that passes continuously into the adjacent marbles and overlying lithologies. This model is consistent with numerous isotope age determinations in the Adirondacks (e.g. Silver, 1968; Hills and Isachsen, 1975). Field evidence suggests that within the southern Adirondacks, the anorthositic suite of rocks was synorogenic and intruded during the F_1 phase of the folding.

(2) Within the metastratified units of the region, we have field evidence for primary facies changes. For example, the well-layered sillimanite-garnet-quartz-feldspar gneisses of the Sacandaga Formation grade laterally into marble-rich units of the Cedar River Fm. exposed north of the Piseco anticline (Figs. 3,4). This transition along strike can be observed just south of the town of Wells, and its recognition is critical to the interpretation of the regional structure. Thus the great thickness of kinzigites (granulite-facies metapelites) south of the Piseco anticline gives way to the north to thinner units marked by marbles, calc-silicates, and quartzites. We interpret this lithologic change as due to a transition from a locally deep basin in which pelitic rocks were accumulating to a shallow-water shelf sequence dominated by carbonates and quartz sands.

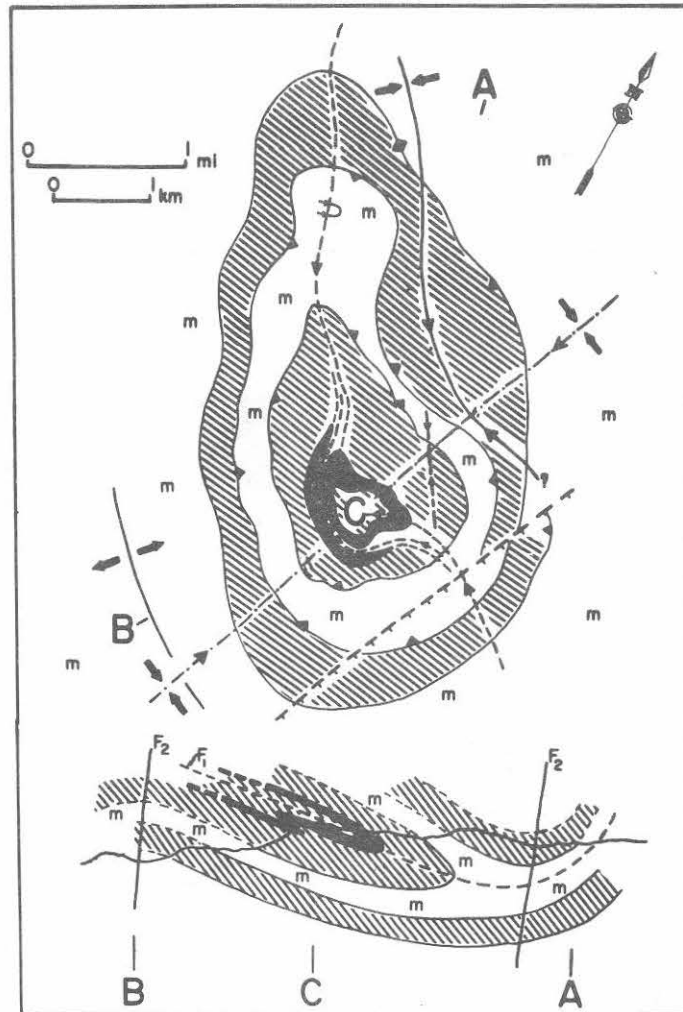

Fig. 8 - Generalized geologic map and cross section of Crane Mt. showing the structural basin produced by interference of F_1 , F_2 and F_3 folds. Charnockite gneiss is shown by the line patterns; marble-rich units by m; and a mixed metasedimentary unit by solid black. A younger normal fault is shown near the eastern edge of the structure. Numbers refer to the dip of the foliation.

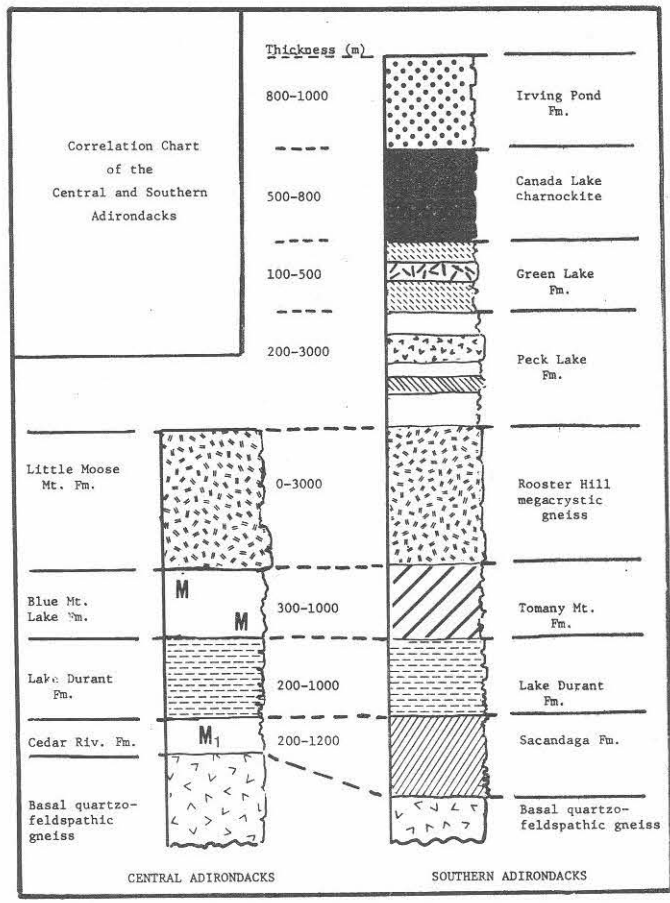

Fig. 9 - Stratigraphic columns for the central and southern Adirondacks. The central Adirondack section is taken from de Waard (1963) and Geraghty (1979).

Given the foregoing information, it has been possible to map and correlate structures and lithologies on either side of the Piseco anticline. In the northwest the sequence on the northern flank proceeds without structural discontinuity into the core of the Little Moose Mt. syncline. There occurs on the southern flank a mirror image of the northwestern lithologic sequence as units are traced towards the core of the Canada Lake nappe. It follows that the Canada Lake nappe and Little Moose Mt. syncline are parts of the same fold (Fig. 10). The amplitude of this fold exceeds 70 km, and it can be followed for at least 150 km along its axial trace. The major F_2 and F_3 folds of the area are exposed through distances of similar magnitude, but their amplitudes are less than those of the F_1 isoclines. The structural framework that emerges is one dominated by exceptionally large folds.

Accepting that the Little Moose Mt. syncline and Canada Lake nappe are the same fold, and noting that the fold axis is not horizontal, it follows that the axial trace of the fold must close in space. The axial trace of the Canada Lake nappe portion of the structure can be followed from west of Gloversville to Saratoga Springs. Therefore, the axial trace of the Little Moose Mt. syncline also must traverse the Adirondacks to the north. Mapping strongly suggests that the hinge line of this fold passes through North Creek and south through Crane Mt. (Fig. 11). From here the axial trace swings eastward along the north limb of the Glens Falls syncline and passes under Paleozoic cover in the vicinity of Lake George. This model is depicted schematically in Figure 11 where the southern Adirondacks are shown as underlain largely by the Canada Lake-Little Moose Mt. syncline. Later folding by F_2 and F_3 events has resulted in regional doming of the F_1 axial surface, and erosion has provided a window through the core of this dome. Note the western extension of the Piseco anticline beneath the Paleozoic cover. This extension is consistent with aeromagnetism of the area.

Currently attempts are underway to synthesize the structural framework of the entire Adirondacks by extending the elements of the present model to other areas. A preliminary version is shown in Figure 12 and suggests that most Adirondack structure is explicable in terms of the four large fold sets described here.

CONCLUDING SPECULATIONS

The ultimate origin of the structural and petrologic features of the Adirondacks remains obscure. A possible clue to the mechanisms involved is Katz's (1955) determination of 36 km as the present depth to the M-discontinuity beneath the Adirondacks. Because geothermometry-geobarometry place the peak of the Grenville metamorphism at 8-9 kb (24-36 km), a double continental thickness is suggested. Such thicknesses presently exist in two types of sites, both plate-tectonic related. The first is beneath the Andes and seems related to magmatic underplating of the South American plate (James, 1971). The second is beneath the Himalayas and Tibet and is due to thickening in response to collision (Dewey and Burke, 1973) or continental underthrusting (Powell and Conaghan, 1973).

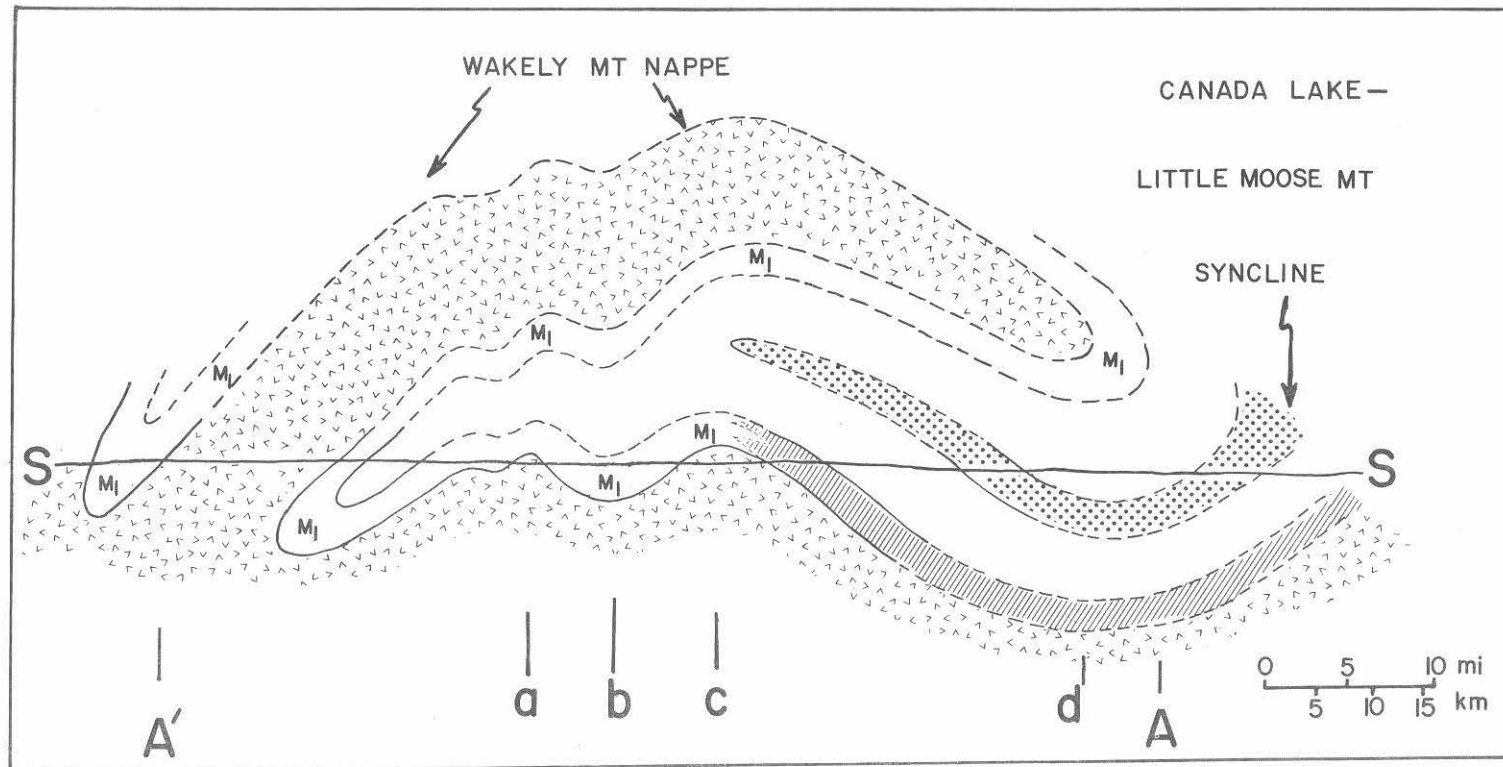

Fig. 10 - Generalized cross section along AA' of Figs. 2, 3 and 4 showing isoclinal folds and subsiding F_2 folds as follows: (a) Spruce Lake anticline; (b) Glens Falls syncline; (c) Piseco anticline; (d) Gloversville syncline. Several map units have been omitted for clarity. Patterned rock unit symbols as in Fig. 2.

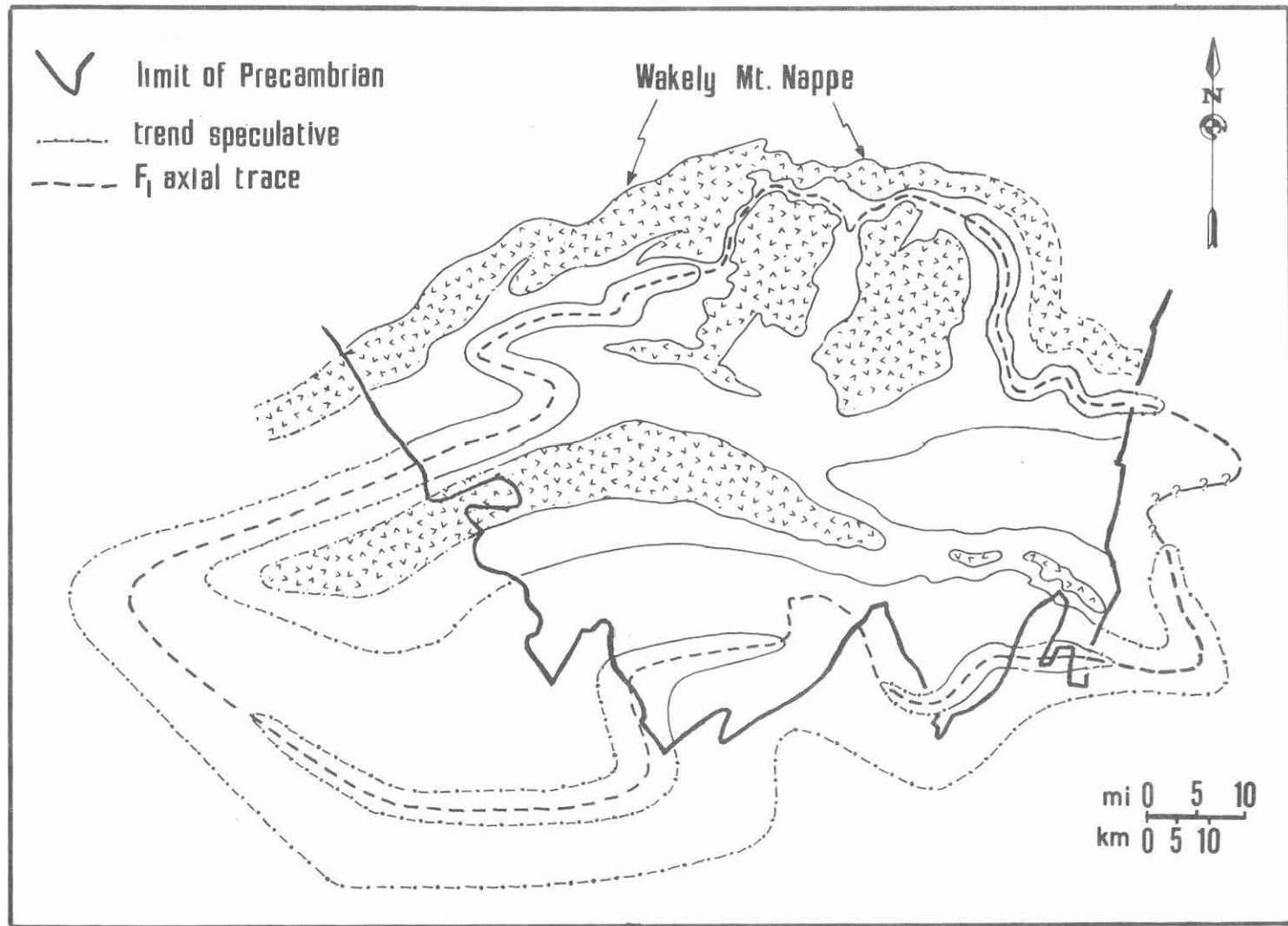
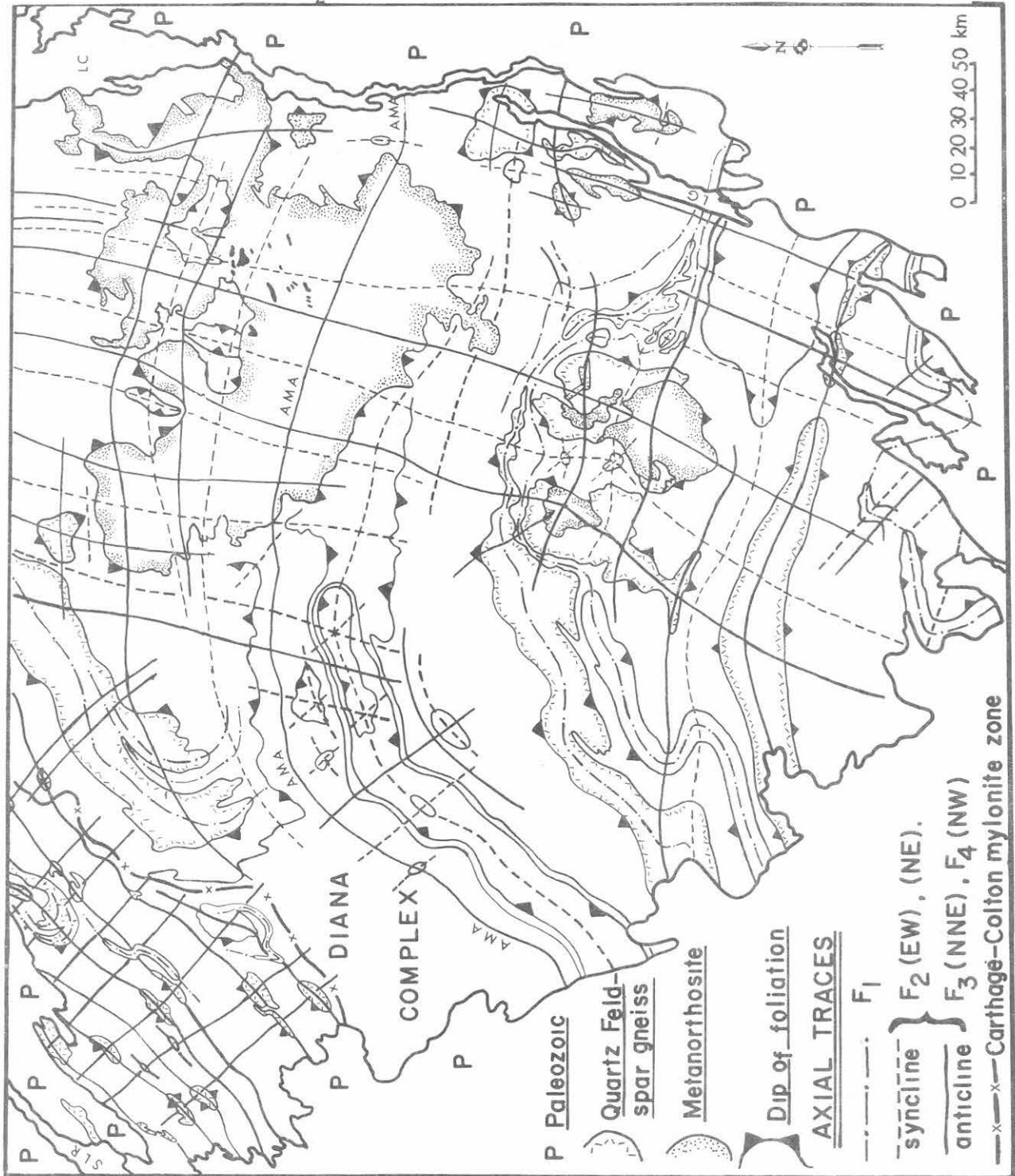

Fig. 11 - Generalized map showing the known axial trace of the Canada Lake-Little Moose Mt. syncline and its projection beneath Paleozoic cover.

Fig. 12 - Suggested framework of ductile deformation in the Adirondacks. White areas within the Adirondack perimeter represent various lithologies, including quartzofeldspathic gneisses not here divided. Black patches within the main anorthosite body are xenoliths and mixed rocks (roof pendants) suggestive of downfolds. SLR-St. Lawrence River; LC-Lake Champlain; LG-Lake George; AMA-Arab Mt. anticline. The northeast trending lines in the northwest Adirondacks (lowlands) represent fold axes thought to be correlative with the F_2 fold set in the Adirondack highlands.



Because of the wide extent of the Grenville metamorphic belt, we prefer the Tibet-India model of crustal thickening in response to a continent-continent collision accompanied by reactivation of basement rocks. Mobilization of the lower crust could lead to the upward displacement of large, recumbent folds in a manner similar to some of Ramberg's (1967) scaled centrifuge experiments.

Although it seems that the tectonic style and framework of the Adirondacks are explained satisfactorily by the Tibetan model, there are no good candidates for even a cryptic Indus-type suture in the area or within the Grenville Province itself. Dewey and Burke (1973) suggest that the collisional suture is most likely buried beneath the folded Appalachians. The Grenville Front itself cannot be a suture, and, as shown by Baer (1977), it has a large component of right lateral motion associated with it. We suggest that the Grenville Front is analogous to features such as the Altyn Tagh Fault in northern Tibet (Molnar and Tapponier, 1975), and, similar to the Altyn Tagh, accommodates the sideways displacement of large crustal blocks by strike-slip motions. In places the Altyn Tagh Fault lies some 1000 km distant from the Indus Suture. A similar distance measured southeast from the Grenville Front would place the corresponding suture beneath the Appalachians. Perhaps it is this buried suture that gives rise to the New York Alabama aeromagnetic lineament of Zietz and King (1977).

ACKNOWLEDGMENTS

This work has been supported by NSF grants GA528 and EAR77-23425.

REFERENCES

- Baer, A.J., 1977, The Grenville Province as a shear zone: *Nature*, v. 267, no. 5609, p. 337-338.
- Bartholomé, P., 1956, Structural geology and petrologic studies in Hamilton Co., New York: unpubl. doctoral dissertation, Princeton Univ., 113 p.
- Bohlen, S.R., and Essene, E.J., 1977, Feldspar and oxide thermometry of granulites in the Adirondack Highlands: *Contr. Min. Petrol.*, v. 62, no. 2, p. 153-169.
- Buddington, A.F., 1972, Differentiation trends and parental magmas for anorthositic and quartz mangerite series, Adirondacks, New York: *Geol. Soc. America Mem.* 132, p. 477-487.
- Cannon, R.S., 1937, Geology of the Piseco Lake quadrangle: *New York State Mus. Bull.* 312, 107 p.
- Cushing, H.P., and Ruedemann, R., 1914, Geology of Saratoga Springs and vicinity: *New York State Mus. Bull.* 169, 177 p.
- de Waard, D., 1962, Structural analysis of a Precambrian fold - The Little Moose Mountain syncline in the southwestern Adirondacks: *Kon. Ned. Akad. Wetensch.*, Amsterdam, Ser. B, v. 65, no. 5, p. 404-417.
- de Waard, D., 1964, Mineral assemblages and metamorphic subfacies in the granulite facies terrain of the Little Moose Mountain syncline, south-central Adirondack highlands: *Proc. Kon. Ned. Akad. Wetensch.*, Amsterdam, Ser. B, v. 67, no. 4, p. 344-362.
- de Waard, D., and Romey, W.D., 1969, Petrogenetic relationships in the anorthosite-charnockite series of the Snowy Mountain Dome, south central Adirondacks, *In* Isachsen, Y.W., ed., *Origin of anorthosites and related rocks*: *New York State Sci. Service Memoir* 18, p. 307-315.
- Dewey, J.F., and Burke, K.C.A., 1973, Tibetan, Variscan, and preCambrian basement reactivation: products of a continental collision: *Jour. Geology*, v. 81, no. 6, p. 683-692.
- Emslie, R.F., 1971, Liquidus relations and subsolidus reactions in plagioclase bearing systems: *Ann. Rept. Director Geophys. Lab., Carnegie Inst. Washington*, 1969-70, p. 148-155.
- Essene, E.J., Bohlen, S.R., Valley, J.W., 1977, Regional metamorphism of the Adirondacks (abst.): *Geol. Soc. America Abstracts with Program*, v. 9, no. 3, p. 260.
- Farrar, S.S., 1976, Petrology and structure of the Glen 7½' quadrangle, southeast Adirondacks, New York: unpubl. doctoral dissertation, SUNY Binghamton, 241 p.
- Foose, M., and Carl, J., 1977, Setting of alaskite bodies in the northwestern Adirondacks, New York: *Geology*, v. 5, no. 2, p. 77-80.
- Geraghty, E.P., 1973, Stratigraphy, structure, and petrology of part of the North Creek 15' quadrangle, southeastern Adirondack Mountains, New York: unpubl. masters thesis, Syracuse Univ., 72 p.

- Geraghty, E.P., 1978, Structure, stratigraphy and petrology of part of the Blue Mountain 15' quadrangle, central Adirondack Mountains, New York: unpubl. doctoral dissertation, Syracuse Univ., 281 p.
- Hills, A., and Isachsen, Y., 1975, Rb/Sr isochron date for mangeritic rocks from the Snowy Mt. massif, Adirondack Highlands and implications from initial Sr87/Sr86 (abst.): Geol. Soc. America Abstracts with Program, v. 7, no. 1, p. 73-74.
- Husch, J., Kleinspehn, K., and McLelland, J., 1975, Anorthositic rocks in the Adirondacks: basement or non-basement? (abst.): Geol. Soc. American Abstracts with Program, v. 7, no. 1, p. 78.
- Isachsen, Y., McLelland, J., and Whitney, P., 1975, Anorthosite contact relationships in the Adirondacks and their implications for geologic history (abst.): Geol. Soc. America Abstracts with Program, v. 7, no. 1, p. 78-79.
- James, D.E., 1971, Andean crustal and upper mantle structure: Jour. Geophys. Res., v. 76, no. 14, p. 3246-3271.
- Katz, S., 1955, Seismic study of crystal structure in Pennsylvania and New York: Bull. Seism. Soc. America, v. 45, p. 303-325.
- Krieger, M.H., 1937, Geology of the Thirteenth Lake Quadrangle, New York: New York State Mus. Bull. 308, 124 p.
- Lettney, C.D., 1969, The anorthosite-charnockite series of the Thirteenth Lake dome, south-central Adirondacks, in Isachsen, Y.W., ed., Origin of anorthosite and related rocks: New York State Mus. and Sci. Service Mem. 18, p. 329-342.
- Martignole, J., and Schrijver, K., 1970, Tectonic setting and evolution of the Morin anorthosite, Grenville Province, Quebec: Bull. Geol. Soc. Finland, v. 42, p. 165-209.
- Mattauer, M., 1975, Sur le mécanisme de formation de la schistosité dans l'Himalaya: Earth Plan. Sci. Lett., v. 28, no. 2, p. 144-154.
- Miller, W.J., 1911, Geology of the Broadalbin quadrangle: New York State Mus. Bull. 153, 65 p.
- Miller, W.J., 1916, Geology of the Lake Pleasant quadrangle: New York State Mus. Bull. 182, 75 p.
- Miller, W.J., 1920, Geology of the Gloversville quadrangle: New York State Mus. and Sci. Service, open-file maps.
- Miller, W.J., 1923, Geology of the Luzerne quadrangle: New York State Mus. Bull., 245-246, 66 p.
- McLelland, J., 1969, Geology of the southernmost Adirondacks: New England Intercol. Geol. Conf., Guidebook, v. 61, sec. 11, p. 1-34.

- McLelland, J., 1972, Stratigraphy and structure of the Canada Lake Nappe: New York State Geol. Assoc., 44th Ann. Meeting, Guidebook, p. E1-E27.
- McLelland, J., and Whitney, P., 1977, Origin of garnet coronas in the anorthosite-charnockite suite of the Adirondacks: *Contr. Min. Petrol.* v. 60, no. 2, p. 161-181.
- Molnar, P., and Tapponier, P., 1975, Cenozoic tectonics of Asia: effects of a continental collision: *Science*, v. 189, no. 4201, p. 419-426.
- Morse, S.A., ed., 1975, Nain anorthosite project Labrador: Field Report 1975: *Contr. No. 26*, Dept. Geology and Geography, Univ. Massachusetts, 93 p.
- Nelson, A.E., 1968, Geology of the Ohio quadrangle: U.S. Geol. Survey Bull. 1251-F, p. F1-F46.
- Powell, C. McA., and Conaghan, P.J., 1973, Plate tectonics and the Himalayas: *Earth Planet. Sci. Lett.*, v. 20, no. 1, p. 1-12.
- Ramberg, H., 1967, Gravity, deformation, and the Earth's crust as studied by centrifuged models: Academic Press, New York, 241 p.
- Silver, L., 1969, A geochronologic investigation of the Anorthosite Complex, Adirondack Mts., New York, *in* Isachsen, Y.W., ed., *Origin of Anorthosites and related rocks*: New York State Mus. and Sci. Service Mem. 18, p. 233-252.
- Simmons, E.C., 1976, Origins of four anorthosite suites: unpubl. doctoral dissertation, SUNY Stony Brook, 190 p.
- Thompson, B., Jr., 1959, Geology of the Harrisburg 15' quadrangle, southern Adirondacks: New York State Mus. and Sci. Service, open-file maps.
- Turner, B.B., 1971, Structural-stratigraphic relationships among metasedimentary, meta-igneous, and other gneissic rocks, southeastern Adirondack Mountains, New York (abst.): *Geol. Soc. America Abstract with Program*, v. 3, no. 1, p. 58.
- Walton, M.S., 1961, Geologic maps of the eastern Adirondacks: New York State Mus. and Sci. Service, open-file maps.
- Walton, M.S. and de Waard, D., 1963, Orogenic evolution of the Precambrian in the Adirondack Highlands: a new synthesis: *Proc. Kon. Ned. Akad. Wetensch.*, Amsterdam, Ser. B, no. 66, p. 98-106.
- Zietz, I., and King, E.R., 1977, The New York-Alabama Lineament: a possible plate boundary (abst.) *Geol. Soc. America Abstracts with Program*, v. 9, no. 3, p. 333.

ROAD LOG

Mileage

0 Junction of Willie Road, Peck Hill Road, and NY Rt. 29A

1.3 Mud Lake to northeast of NY Rt. 29A

2.8 Peck Lake to northeast of NY Rt. 29A

3.6 Stop 1. Peck Lake Fm.

This exposure along Rt. 29A just north of Peck Lake is the type locality of the sillimanite-garnet-biotite-quartz-feldspar gneisses (kinzigites) of the Peck Lake Fm. In addition, there are exposed excellent minor folds of several generations. Note that the F_1 folds rotate an earlier foliation.

The white quartzo-feldspathic layers in the kinzigites consist of quartz, two feldspars, and garnet and are believed to be anatectic. Note that fish-hook terminations on some of these suggest that they have been transposed. It is also clear that these anatectites have been folded by F_1 indicating a pre- F_1 metamorphic event(s). In a similar fashion some garnets in the rock appear to be flattened while others do not.

6.1 Junction NY Rt. 29A and NY Rt. 10

8.0 Nick Stoner's Inn on west side of NY Rt. 29A-10

8.6 Stop 2. Irving Pond Fm., .5 mile north of Nick Stoner's Inn, Canada Lake.

The outer portion of the Irving Pond Fm. is exposed in low cuts along the east side of Rt. 29A just prior to the crest in the road heading north.

At the southern end of the cut typical, massive quartzites of the Irving Pond are seen. Proceeding north the quartzites become "dirtier" until they are essentially sillimanite-garnet-biotite-feldspar gneisses (kinzigites).

At the northern end of the cut, and approximately on the Irving Pond/Canada Lake Fm. contact there occurs an excellent set of F_1 minor folds. Polished slabs and thin sections demonstrate that these fold an earlier foliation defined by biotite flakes and flattened quartz grains.

The Irving Pond Fm. is the uppermost unit in the stratigraphy of the southern Adirondacks. Its present thickness is close to 1000 meters, and it is exposed across strike for approximately 4000 meters. Throughout this section massive quartzites dominate.

8.8 Stop 3. Canada Lake Charnockite

These large roadcuts expose the type section of the Canada Lake charnockite. Lithologically the charnockite consists of 20-30% quartz, 40-50% mesoperthite, 20-30% oligoclase, and 5-10% mafics. The occurrence of orthopyroxene is sporadic. These exposures exhibit the olive-drab coloration that is typical of charnockites. Note the strong foliation in the rock.

Although no protolith is known with certainty for these rocks a metavolcanic history is suggested by their homogeneity and lateral continuity.

10.0 Canada Lake Store. Good exposures of Royal Mt. member of Green Lake Fm.

11.8 Pine Lake, Junction NY Rt 29A and NY Rt. 10. Proceed north on NY Rt. 10.

17.5 Stop 4. Rooster Hill megacrystic gneiss at the north end of Stoner Lake.

This distinctive unit is believed to be, in part, correlative with the Little Moose Mt. Fm. Here the unit consists of a monotonous series of unlayered to poorly layered gneisses characterized by large (1-4") megacrysts of perthite and microcline perthite. For the most part these megacrysts have been flattened in the plane of foliation. However, a few megacrysts are situated at high angles to the foliation. The groundmass consists of quartz, oligoclase, biotite, hornblende, garnet, and occasional orthopyroxene. An igneous rock analogue would be quartz-monzonite.

The origin of the Rooster Hill is obscure. Its homogeneity over a thickness approaching 2.5 km suggests an igneous parentage. This conclusion gains support from the presence of localities where megacrysts appear to retain a random orientation, and from the occasional presence of what may be drawn out xenoliths of biotitic or amphibolitic gneisses. However, these features may be explained by other models. The contacts of the Rooster Hill are always conformable with enclosing units, and this suggests a metastratified (metavolcanic?) origin. However, the anorthosites of the region also show conformable contacts, and this may, in part, be due to tectonic flattening.

Recently Eckelmann (pers. comm.) has studied zircon population morphologies in the Rooster Hill and similar lithologies. His results strongly suggest an igneous plutonic origin. This would be consistent with the igneous origin assigned the Hermon granite of the northwest Adirondacks - a rock that is markedly similar to the Rooster Hill.

- 20.0 Low roadcut in kinzigites of Tomany Mt. Fm.
- 21.4 Avery's Hotel on west side of NY Rt. 10
- 22.5 Long roadcuts of quartzofeldspathic gneisses and metasediments of Lake Durant Fm. intruded by metagabbro and anorthositic metagabbro.
- 23.6 Roadcut of anorthositic metagabbro and metanorite.
- 23.9 Roadcut on west side of highway shows excellent examples of anorthositic gabbros intrusive into layered pink and light green quartzo-feldspathic gneisses. The presence of pegmatites and cross-cutting granitic veins is attributed to anatexis of the quartzo-feldspathic gneisses by the anorthositic rocks.
- 24.0 Stop 5. Lake Durant and Sacandaga Fms. intruded by anorthositic gabbros and gabbroic anorthosites.

These roadcuts are located on Rt. NY 10 just south of Shaker Place.

The northernmost roadcut consists of a variety of metasedimentary rocks. These lie directly above the Piseco anticline and are believed to be stratigraphically equivalent to the Sacandaga Formation. The outcrop displays at least two phases of folding and their related fabric elements. These are believed to be F_1 and F_2 . A pre- F_1 foliation is thought to be present. Both axial plane foliations are well developed here. Several examples of folded F_1 closures are present and F_1 foliations (parallel to layering) can be seen being folded about upright F_2 axial planes.

Farther to the south, and overlooking a bend in the west branch of the Sacandaga River, there occurs a long roadcut consisting principally of pink and light green quartzo-feldspathic gneisses belonging to the Lake Durant Fm. About half-way down this roadcut there occurs a large and impressive boudin of amphibolite and diopsidic gneiss. To the north of the boudin the quartzo-feldspathic gneisses are intruded pervasively by anorthositic gabbros, gabbroic anorthosites, and various other related igneous varieties. At the north end of the cut and prior to the metastratified sequences these intrusives can be seen folded by upright fold axes. They are crosscut by quartzo-feldspathic material.

Within this general region the Lake Durant Fm. and other quartzo-feldspathic gneisses seem to have undergone substantial anatexis. This is suggested by the "nebular" aspect of the rocks. Good examples of this are seen in the manner in which green and pink portions of the quartzo-feldspathic gneisses mix. Note also the clearly cross-cutting relationships between quartzo-feldspathic gneiss and mafic layers at the south end of the roadcut. Here it seems that mobilized Lake Durant is cross-cutting its own internal stratigraphy. Also note that the

quantity of pegmatitic material is greater than usual. This increase in anatectic phenomena correlates closely with the appearance of extensive metagabbroic and metanorthositic rocks in this area. We believe that these provided a substantial portion of the heat that resulted in partial fusion of the quartzo-feldspathic country rock.

31.0 Red-stained basal quartzofeldspathic gneissesses that have been faulted along NNE fractures.

31.5 Junction NY Rt. 10 and NY Rt. 8. End Rt. 10. Turn east on NY Rt. 8.

33.0 Stop 6: Core rocks of the Piseco anticline.

Hinge line of Piseco anticline near domical culmination at Piseco Lake. The rocks here are typical basal quartzo-feldspathic gneisses such as occur in the Piseco anticline and in other large anticlinal structures, for example Snowy Mt. dome, Oregon dome.

The pink "granitic" gneisses of the Piseco anticline do not exhibit marked lithologic variation. Locally grain size is variable and in places megacrysts seem to have been largely granulated and only a few small remnants of cores are seen. The open folds at this locality are minor folds of the F_2 event. Their axes trend N70W and plunge 10-15° SE parallel to the Piseco anticline.

The most striking aspect of the gneisses in the Piseco anticline is their well-developed lineation. This is expressed by rod, or pencil-like, structures. These may consist of alternating ribbons of quartzite, quartzo-feldspathic gneiss, and biotite-rich layers. In many instances these ribbons represent transposed layering on the highly attenuated limbs of early, isoclinal minor folds. Near the northeast end of the roadcut such minor folds are easily seen due to the presence of quartzite layers in the rock. Slabbed and polished specimens from this and similar outcrops demonstrates that these early folds are exceedingly abundant in the Piseco anticline. Examination of these folds shows that the dominant foliation in the rock is axial planar to them. Similarly, layer transportation is related to flattening parallel to the axial planes of the early folds. The intersection of this axial plane foliation and compositional surfaces helps to define the strong lineation in the outcrop. Also present is an earlier foliation subparallel to the one associated with the visible folds. Again intersections between these foliations, compositional surfaces, etc., result in a strong intersection lineation. In addition to this a number of rod-like lineations are probably the hinge line regions of isoclinal minor folds which are difficult to recognize because of relative lithologic homogeneity. Lineation in the outcrop is intensified further by the fact the upright and relatively open F_2 folds are coaxial with F_1 . Thus the intersection of the F_2 axial planar folia-

tion with earlier foliations results in a lineation parallel to the F_2 trend. Moreover, F_2 minor folds may be of the crenulation variety and their sharp hinge lines define a lineation in the earlier foliation.

In summary, a number of parallel elements combine to produce an extremely strong lineation in the Piseco anticline. Past observers have remarked that the lineation appears to be the result of stretching parallel to the long axis of the Piseco dome. However, the lineation is probably unrelated to "stretching" and is explained more readily as an intersection lineation of planar fabrics. Moreover, the intensity of the lineation is more the result of the early recumbent folding and flattening than it is of the later, coaxial F_2 Piseco anticline.

43.5 Junction NY Rt. 8 and NY Rt. 30 in Speculator. Head southeast on NY Rt. 8-30.

47 Stop 7. Northern intersection of old Rt. NY 30 and new Rt. NY 30, 3.3 miles east of Speculator, New York.

The Blue Mt. Lake Fm. is exposed in roadcuts on both sides of the highway. These exposures show typical examples of the extreme ductility of the carbonate-rich units. The south wall of the roadcut is particularly striking, for here relatively brittle layers of garnetiferous amphibolite have been intensely boudinaged and broken. The marbles, on the other hand, have yielded plastically and flowed with ease during the deformation. As a result the marble-amphibolite relationships are similar to those that would be expected between magma and country rock. Numerous rotated, angular blocks of amphibolite are scattered throughout the marble in the fashion of xenoliths in igneous intrusions. At the eastern end of the outcrop tight isoclinal folds of amphibolite and metapelitic gneisses have been broken apart and rotated. The isolated fold noses that remain "floating" in the marble have been aptly termed "tectonic fish." The early, isoclinal folds rotate on earlier foliation.

Near the west end of the outcrop a deformed layer of charnockite is well exposed. In other places the charnockite-marble inter-layering occurs on the scale of one to two inches.

Exposed at several places in the roadcut are striking, cross-cutting veins of tourmaline and quartz displaying a symplectic type of intergrowth. Other veins include hornblende and sphene bearing pegmatites.

Commonly included in the Blue Mt. Lake Fm., but not exposed here, are quartzites, kinzigites; sillimanite rich, garnetiferous, quartz-microcline gneisses; and fine grained garnetiferous leucogneisses identical to those characterizing the Sacandaga Fm. These lithologies may be seen in roadcuts .5 mile to the south.

Almost certainly these marbles are of inorganic origin. No calcium carbonate secreting organisms appear to have existed during the time in which these carbonates were deposited (> 1 b.y. ago). Presumably the graphite represents remains of stromatolite-like binding algae that operated in shallow water, intertidal zones. If so, the other roadcut lithologies formed in this environment as well. This seems reasonable enough for the clearly metasedimentary units such as the quartzites and kinzigites. The shallow water environment is much more interesting when applied to the charnockitic and amphibolite layers. The fine scale layering, and ubiquitous conformity of these, strongly suggests that they do not have an intrusive origin. Perhaps they represent the metamorphosed products of volcanic material in a shelf like environment. Such intercalation is now occurring in many island arc areas where shallow water sediments cover, and in turn are covered by, ash and lava. Alternatively they may represent metasediments.

47.5 Extensive roadcuts in lower part of Blue Mt. Lake Fm. Quartzites, kinzigites, and leucogneisses dominate. Minor marble and calcsilicate rock is present.

47.9 Large roadcuts in lower Lake Durant Fm. Pink, well-layered quartzo-feldspathic gneisses with subordinate amphibolite and calcsilicate rock.

49.0 Stop 8. One half mile south of southern intersection of old Rt. 30 and with new Rt. 30.

On the west side of the road small roadcut exposes an excellent example of Adirondack anorthositic gneiss intermediate in character between the so-called Marcy type (uncrushed) and the Whiteface type (crushed). About 50% of the rock consists of partially crushed crystals of andesine plagioclase. Some of these crystals appear to have measured from 6-8" prior to cataclasis. Excellent moonstone sheen can be seen in most crystals. In places ophitic to subophitic texture has been preserved with the mafic phase being represented by orthopyroxene.

In addition to the coarse grained anorthosite there exists a fine grained phase and a clearly crosscutting set of late orthopyroxene rich dikes. The latter may represent a late mafic differentiate related to cotectic liquids responsible for the ophitic intracrystalline rest magma. This would be consistent with the iron enrichment trend characteristic of Adirondack igneous differentiation. The fine-grained phase may have intruded early in the sequence, but this is uncertain.

Near road level there can be found several inclusions of calcsilicate within the anorthositic rocks. These are believed to have been derived from the Cedar River Fm. and are consistent with a non-basement status for the anorthosite.

The upper, weathered surface of the outcrop affords the best vantage point for studying the textures and mineralogy of the anorthositic rocks. In several places there can be seen excellent examples of garnet coronas of the type that are common throughout Adirondack anorthosites. These coronas are charac-

terized by garnet rims developed around iron-titanium oxides and pyroxenes. Recently McLelland and Whitney (1977) have succeeded in describing the development of these coronas according to the following generalized reaction:

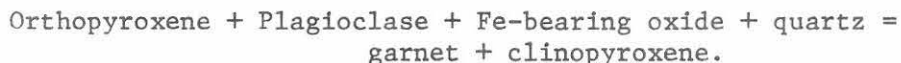

This reaction is similar to one proposed by de Waard (1965) but includes Fe-oxide and quartz as necessary reactant phases. The products are typomorphic of the garnet-clinopyroxene sub-facies of the granulite facies (de Waard 1965). The application of various geothermometers to the phases present suggests that the P,T conditions of metamorphism were approximately 8 Kb and $700 \pm 50^{\circ}\text{C}$ respectively.

- 51.0 Cedar River Fm. Minor marble, amphibolite, and calcsilicate rock. Predominantly very light colored sillimanite-garnet-quartz-k-feldspar leucogneisses.
- 52.0 Junction NY Rt. 8 and NY Rt. 30. Continue south on NY Rt. 30. To the west of the intersection are roadcuts in leucogneisses of the Blue Mt. Lake Fm. A large NNE normal fault passes through here and fault breccias may be found in the roadcut and the woods beyond.
- 52.5 Entering Little Moose Mt. Fm. on northern limb of the Glens Falls syncline. Note that dips of foliation are to the south.
- 54.8 Entering town of Wells which is situated on a downdropped block of lower Paleozoic sediments. The minimum displacement along the NNE border faults has been determined to be at least 1000 meters.
- 58.3 Silver Bells ski area to the east. The slopes of the ski hill are underlain by coarse anorthositic gabbro intrusive into the Blue Mt. Lake Fm.
- 60.3 Entrance to Sacandaga public campsite. On the north side of NY Rt. 30 are quartzo-feldspathic gneisses and calcsilicate rocks of the Lake Durant Fm. An F_1 recumbent fold trends sub-parallel to the outcrop and along its hinge line dips become vertical.
- 60.8 Gabbro and anorthositic gabbro.
- 62.0 Stop 9. Pumpkin Hollow. Large roadcuts on the east side of Rt. 30 expose excellent examples of the Sacandaga Fm. At the northern end of the outcrop typical two pyroxene-plagioclase granulites can be seen. The central part of the outcrop contains good light colored sillimanite-garnet-microcline-quartz gneisses (leucogneisses). Although the weathered surface of these rocks are often dark due to staining, fresh samples display the typical light color of the Sacandaga Fm. The characteristic excellent layering of the Sacandaga Fm. is clearly developed. Note the strong flattening parallel to layering.

Towards the southern end of the outcrop calc-silicates and marbles make their entrance into the section. At one fresh surface a thin layer of diopsidic marble is exposed. NO HAMMERING, PLEASE. Many "punky" weathering layers in the outcrop contain calc-silicates and carbonates.

At the far southern end of the roadcut there exists an exposure of the contact between the quartzo-feldspathic gneisses of the Piseco anticline and the overlying Sacandaga Fm. The hills to the south are composed of homogeneous quartzo-feldspathic gneisses coring the Piseco anticline (note how ruggedly this massive unit weathers). The Sacandaga Fm. here has a northerly dip off the northern flank of the Piseco anticline and begins its descent into the southern limb of the Glens Falls syncline.

No angular discordance or other indications of unconformity can be discerned at the base of the Sacandaga Fm. However, this does not preclude the prior existence of an angular discordance which may have been swept into pseudoconformity by tectonism.

Along most of the roadcut there can be found excellent examples of faults and associated pegmatite veins. Note that the drag on several of the faults gives conflicting senses of displacement. The cause of this is not known to the author. Also note the drag folds which indicate tectonic transport towards the hinge line of the Piseco anticline.

- 62.5-67.0 All exposures are within the basal quartzo-feldspathic gneisses at the core of the Piseco anticline.
- 67.0 Re-enter the Sacandaga Fm. Dips are now southerly.
- 68.0 In long roadcuts of southerly dipping quartzo-feldspathic gneisses of Lake Durant Fm.
- 70.4 Cross bridge over Sacandaga River.
- 74.4 Bridge crossing east corner of Sacandaga Reservoir into Northville, N.Y.

END LOG